

Fundamentals of Matrix Converter

The matrix converter has several advantages over traditional rectifier-inverter type power frequency converters. It provides sinusoidal input and output waveforms, with minimal higher order harmonics and no sub harmonics; it has inherent bi-directional energy flow capability; the input power factor can be fully controlled. Last but not least, it has minimal energy storage requirements, which allows to get rid of bulky and lifetime-limited energy-storing capacitors.

But the matrix converter has also some disadvantages. First of all it has a maximum input output voltage transfer ratio limited to $\cong 87\%$ for sinusoidal input and output waveforms. It requires more semiconductor devices than a conventional AC-AC indirect power frequency converter, since no monolithic bi-directional switches exist and consequently discrete unidirectional devices, variously arranged, have to be used for each bi-directional switch. Finally, it is particularly sensitive to the disturbances of the input voltage system.

The topology

The matrix converter consists of 9 bi-directional switches that allow any output phase to be connected to any input phase. The circuit scheme is shown in Fig.1. The input terminals of the converter are connected to a three phase voltage-fed system, usually the grid, while the output terminal are connected to a three phase current- fed system, like an induction motor might be. The capacitive filter on the voltage- fed side and the inductive filter on the current- fed side represented in the scheme of Fig. 1 are intrinsically necessary. Their size is inversely proportional to the matrix converter switching frequency.

It is worth noting that due to its inherent bi-directionality and symmetry a dual connection might be also feasible for the matrix converter: a current- fed system at the input and a voltage- fed system at the output.

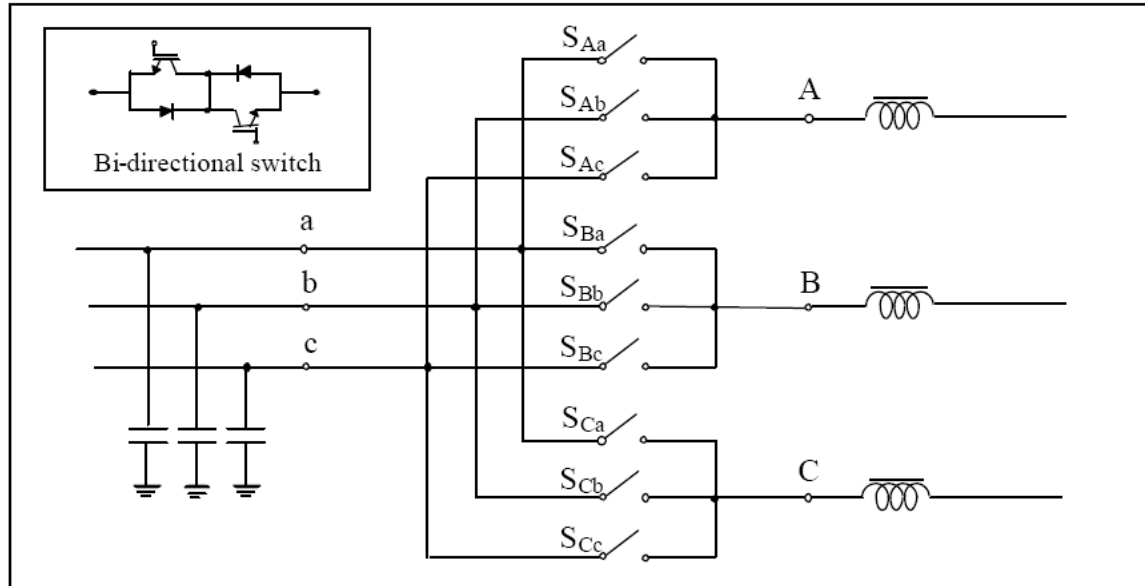

Fig.1 Circuit scheme of a three phase to three phase matrix converter. a,b,c are at the input terminals. A,B,C are at the output terminals.

With nine bi-directional switches the matrix converter can theoretically assume 512 (2^9) different switching states combinations. But not all of them can be usefully employed. Regardless to the control method used, the choice of the matrix converter switching states combinations (from now on simply matrix converter configurations) to be used must comply with two basic rules. Taking into account that the converter is supplied by a voltage source and usually feeds an inductive load, the input phases should never be short-circuited and the output currents should not be interrupted. From a practical point of view these rules imply that one and only one bi-directional switch per output phase must be switched on at any instant. By this constraint, in a three phase to three phase matrix converter 27 are the permitted switching combinations.

The performance

This section gives a short description of what are the performances of a matrix converter. A qualitative analysis of some performance parameters is carried out. Some numerical results based on a simplified model of a matrix converter system are also shown.

The output voltage

Since no energy storage components are present between the input and output side of the matrix converter, the output voltages have to be generated directly from the input voltages. Each output voltage waveform is synthesized by sequential piecewise sampling of the input voltage waveforms. The sampling rate has to be set much higher than both input and output frequencies, and the duration of each sample is controlled in such a way that the average value of the output waveform within each sample period tracks the desired output waveform. As consequence of the input-output direct connection, at any instant, the output voltages have to fit within the enveloping curve of the input voltage system. Under this constraint, the maximum output voltage the matrix converter can generate without entering the over- modulation range is equal to $\sqrt{3}/2$ of the maximum input voltage: this is an intrinsic limit of matrix converter and it holds for any control law.

Entering in the over- modulation range, thus accepting a certain amount of distortion in the output voltages and input currents, it is possible to reach higher voltage transfer ratio. In Fig.2 the output voltage waveform of a matrix converter is shown and compared to the output waveform of a traditional voltage source inverter (VSI). The output voltage of a VSI can assume only two discrete fixed potential values, those of the positive and negative DC-bus. In the case of the matrix converter the output voltages can assume either input voltage a, b.

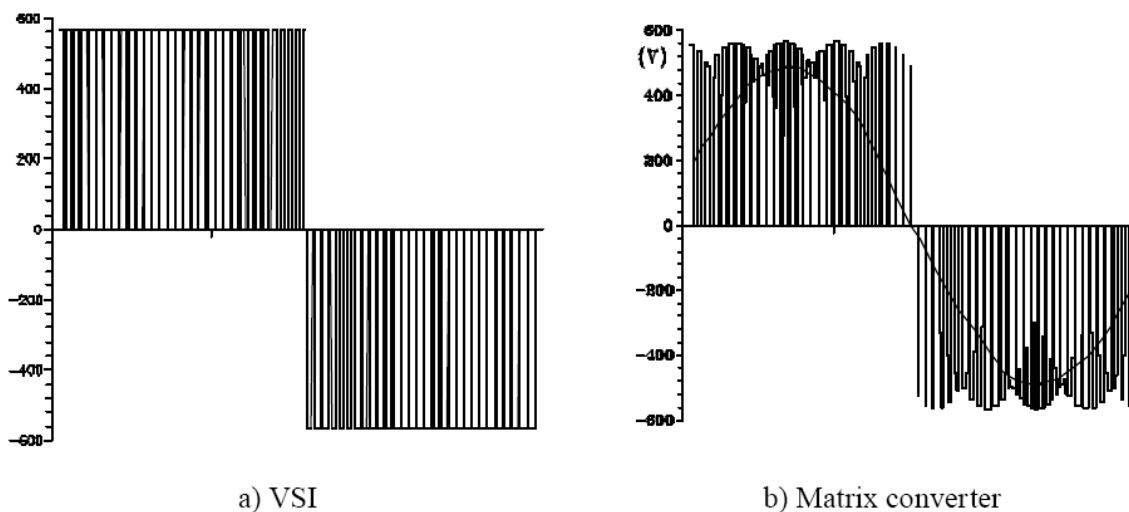

Fig.2 Output voltage waveforms generated by a VSI and a matrix converter

The input current

Likewise to the output voltages, the input currents are directly generated by the output currents, synthesized by sequential piecewise sampling of the output current waveforms. If the switching frequency of the matrix converter is set to a value that is much higher than the input and output frequency, the input currents drawn by the converter are sinusoidal: their harmonic spectrum consists only of the fundamental desired component plus a harmonic content around the switching frequency.

In Fig. 3 the input current drawn by a matrix converter for a 2 kHz switching frequency is shown. It can be noted that the amplitude of the switching harmonic components is comparable to the fundamental amplitude. It is then obvious that an input filter is needed in order to reduce the harmonic distortion of the input line current to an acceptable level. It follows that care should be used in speaking about matrix converters as an “all silicon” solution for direct AC/AC power conversion, since some reactive components are needed.

The matrix converter performance in terms of input currents represent a significant improvement with respect to the input currents drawn by a traditional VSI converters with a diode bridge rectifier, whose harmonic spectrum shows a high content of low-order harmonics. By the light of the standards related to power quality and harmonic distortion of the power supply this is a very attractive feature of matrix converter.

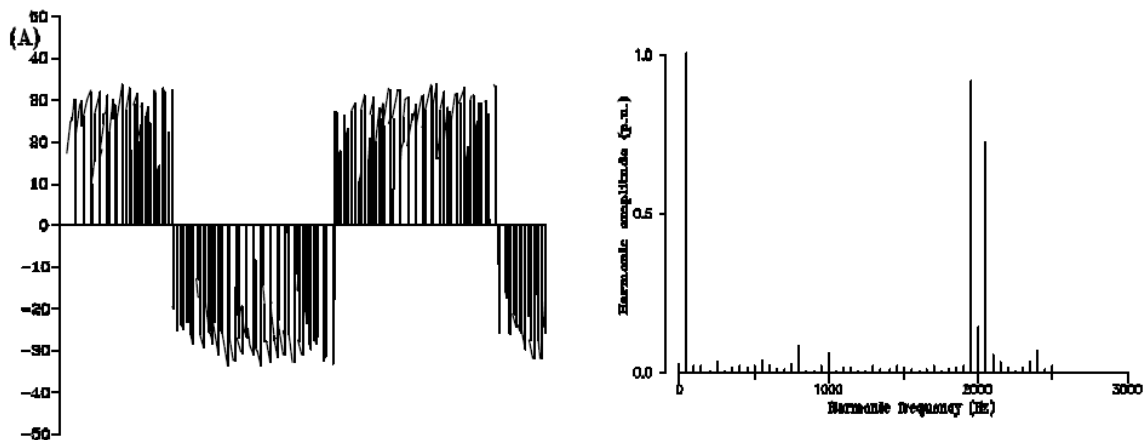

Fig. 3 Matrix converter input current and harmonic spectrum. Switching frequency 2kHz.

The input power factor control

The input power factor control capability is another attractive feature of matrix converters, which holds for most of the control algorithms proposed in literature. Despite of this common capability it is worth noting that a basic difference exists with respect to the load displacement angle dependency.

For instance, the algorithm proposed in does not require the knowledge of the load displacement angle in order to fully control the input power factor. On the contrary, the algorithm in does require the knowledge of the load displacement angle whenever the reference input power factor is different from unity. From an algorithm computational burden point of view this is a drawback, since it implies additional quite heavy calculations.

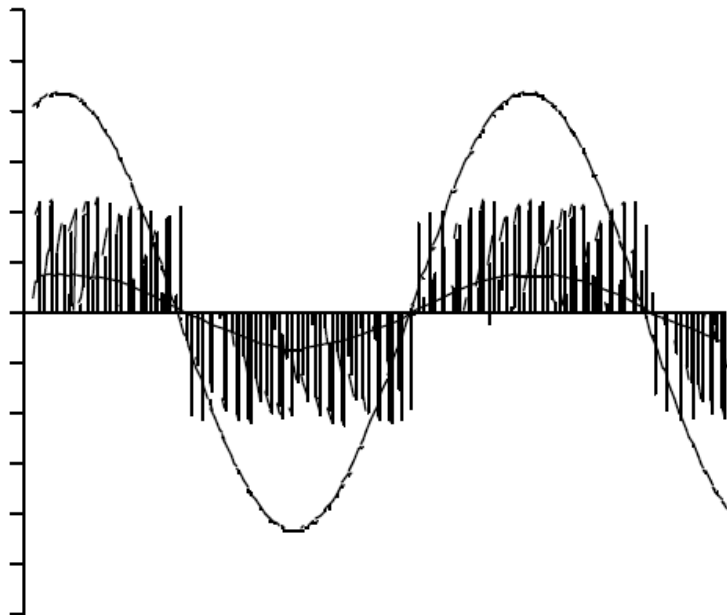

Fig.4 Matrix converter input line-to-neutral voltage, instantaneous input current and its average value. Switching frequency 2kHz.

Implementation of the Matrix Converter

Looking at the basic features of the matrix converter that have been briefly described in the previous sections it might be surprising to establish that this converter topology, today, has not found a wide utilization yet. The reasons have to be sought in a number of practical implementation problems that have slowed down the development of this technology.

The bi-directional switch realization and commutation

A first key problem is related to the bi-directional switches realization. By definition, a bidirectional switch is capable of conducting currents and blocking voltages of both polarities, depending on control actual signal. But at present time a true bi-directional switch is still not available on the market and thus it must be realized by the combination of conventional unidirectional semiconductor devices. Fig.5 shows different bi-directional switch configurations which have been used in prototype and/or proposed in literature.

Another problem, tightly related to the bi-directional switches implementation, which has represented a main obstacle to the industrial success of the matrix converter, is the commutation problem. The commutation issue basically rises from the absence, in the matrix converters, of static freewheeling paths. As consequence it becomes a difficult task to safely commute the current from one bi-directional switch to another, since a particular care is required in the timing and synchronization of the switches command signals.

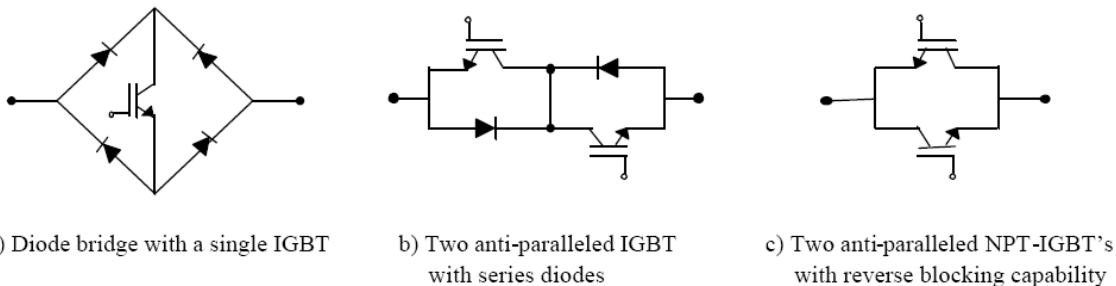

Fig. 5 Possible discrete implementations of a bi-directional switch.

The input filter issue

Although the matrix converter is sometimes presented as an all silicon solution, due to the lack of the bulky and expensive DC-link capacitors of traditional indirect frequency converter, it also requires a minimum of reactive components, represented by the input filter.

The input filter acts as an interface between the matrix converter and the AC mains (Fig. 6). Its basic feature is to avoid significant changes of the input voltage of the converter during each PWM cycle, and to prevent unwanted harmonic currents from flowing into AC mains. As matter of fact, due to the discontinuous input currents, the

matrix converter behaves as a source of current harmonics, which are injected back into the AC mains. Since these current harmonics result in voltage distortions that affect the overall operation of the AC system, they have to be reduced.

The principal method of reducing the harmonics generated by static converters is provided by input filter using reactive storage elements.

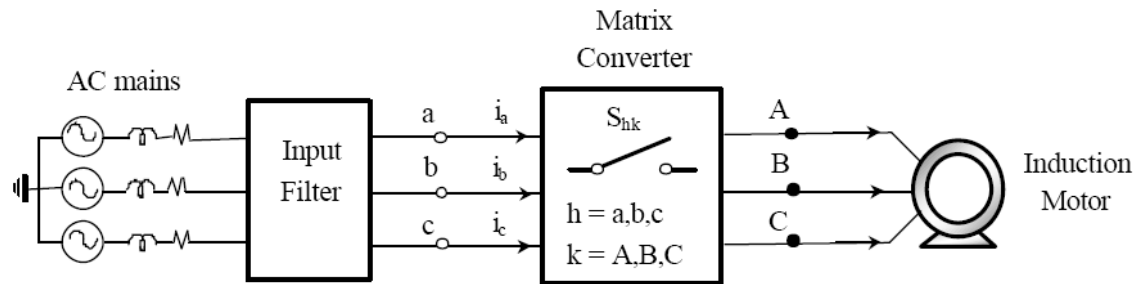

Fig.6 Schematic representation of a matrix converter adjustable speed drive.

The problem of the input filter design for a matrix converter has been addressed in quite few papers and looking at the literature, different configurations have been proposed for the matrix converter input filter. Such differences are a consequence of different design criteria, or at least differently weighted, different switching frequencies and different modulation strategies. In Fig.7 three input filter configurations used in matrix converter prototype are shown.

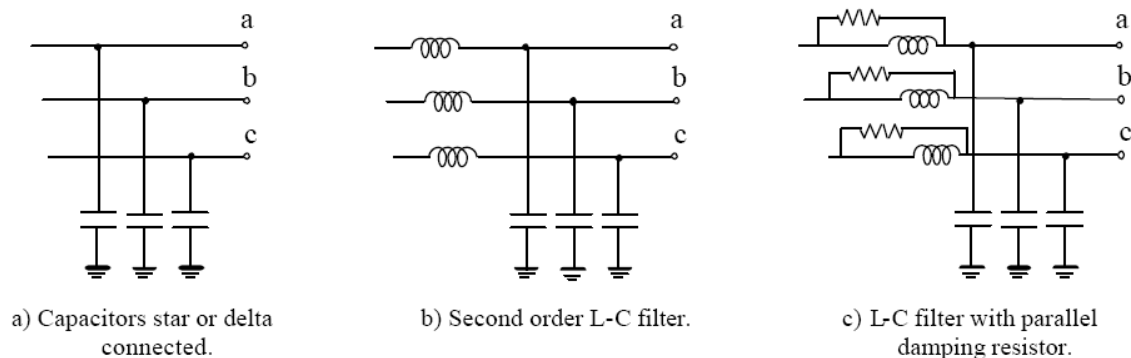

Fig. 7 Basic input filter configurations used in matrix converter prototypes.

In general, the design of an input filter for static power converters operating from an ac power system has to meet three main requirements:

- 1) Carrying out the required switching noise attenuation;

- 2) Having a low input displacement angle between filter input voltage and current;
- 3) Guaranteeing overall system stability.

In addition to these requirements, a set of considerations related to cost, voltage attenuation, system efficiency and filter parameter variation have to be made for an optimized input filter design.

The first requirement is usually dictated by the EMI control standards: the input filter has to reduce the input current and output voltage total harmonic distortion below given values. In order to achieve this result, the resonant frequency of the filter has to be positioned accordingly to the converter switching frequency and its PWM pattern. When the input current harmonic spectrum generated by the converter is known, the filter resonance frequency is positioned where no unwanted harmonic components exist, which is usually the frequency range comprised between the fundamental and the switching frequency. In practice, due to the presence of imperfections and asymmetry in gating signals as well as implementation inaccuracies, some unwanted or uncharacteristic harmonics with small amplitude might exist in this region. If no damping is provided, these unwanted harmonics can be amplified by the filter to unacceptable level. On the other hand, a highly damped filter could not meet the harmonics attenuation requirements.

With regard to the matrix converter, Fig.7 shows that single stage filter configurations have been basically used to provide harmonic attenuation, but in the light of the new and future EMI standards such configurations are not expected either to meet the regulations or to be economically convenient.

With regard to the second requirement, it follows by the presence in the filter of reactive storage elements. As it can be clearly seen from Fig.7, a phase displacement of the filter input current with respect to the line-to-neutral voltage proportional to the filter capacitance value is always present. Thus, in order to maintain high input power factor the capacitor size has to be minimized. This typically translates into an upper limit for filter capacitor value.

Yet, the capacitor size limitation has several implications on the filter design. In order to meet the required attenuation specifications, the filter inductor size increases, which results in the overall filter size increase? Moreover, the input filter output impedance,

related to the total filter capacitance, is more difficult to control, potentially resulting in converter instability.

As far as the matrix converter is concerned, a high displacement angle of the input line current due to the input filter capacitance component might be compensated by the matrix converter, setting as reference for the input current a lagging displacement angle. But in this way the maximum voltage transfer ratio for the converter would be significantly reduced. Therefore, even for the matrix converter, the upper limit of the input filter capacitance is set by the minimum acceptable AC mains power factor.

The last but not least requirement refers to the control of the impedance interaction between the input filter and the converter. In general, the filter output impedance should be as low as possible when compared to the converter input impedance. The filter output impedance can be reduced by increasing the filter capacitor size. Practically the impedance interaction constraint determines the lower bound on the filter capacitor value. Additionally, proper filter pole damping is extremely important for achieving low filter output impedance for all frequencies and, thus, overall system stability.

With regard to the matrix converter, although the stability issue did not appear in the relevant literature, it is not immune from this phenomenon. In conclusion, an optimized design of the matrix converter input filter is a quite difficult task, since relies on a system level approach and in the light of the new coming harmonic and EMI reduction standards it can be somehow considered an outstanding issue.